

REVISIONS			
REV	DESCRIPTION	DATE	APPROVED

- NOTES :
- 1 B Dim. not needed for flanges / plates less than .400 thick.
  - 2 Space required between connectors : 19C = .250
  - 3 Flanges .800 thick or larger, Contact Accu-Glass Products Inc.

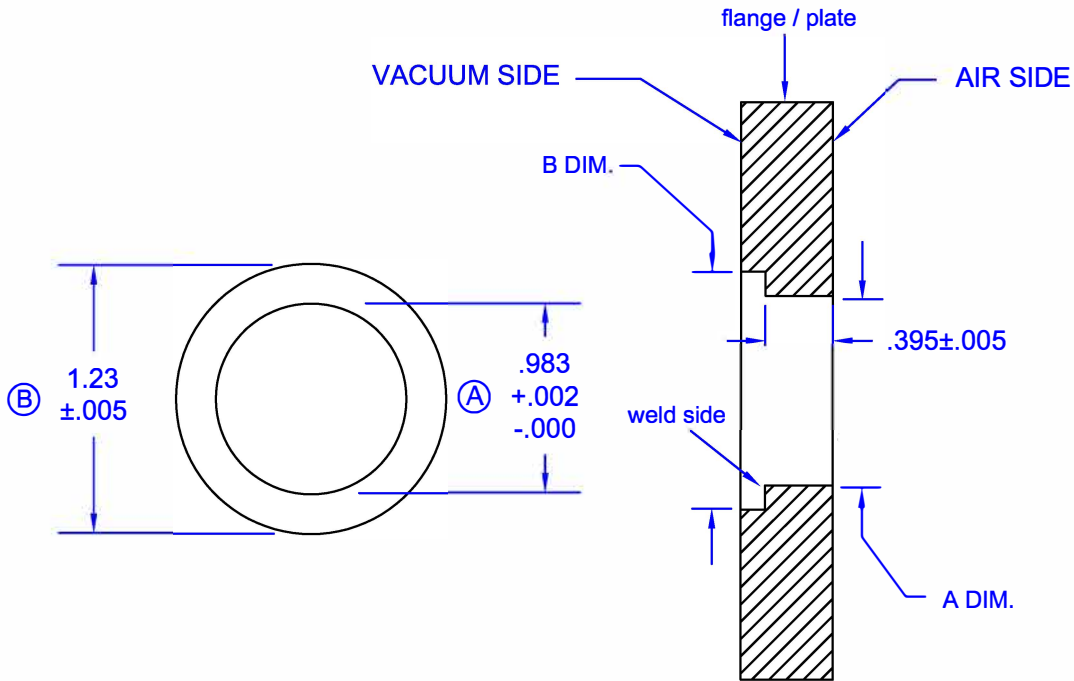

- 1 Pin Position Mark Both Sides.
- 2 4-40 UNC Thread
- 3 0.040 Pin Dia TYP.

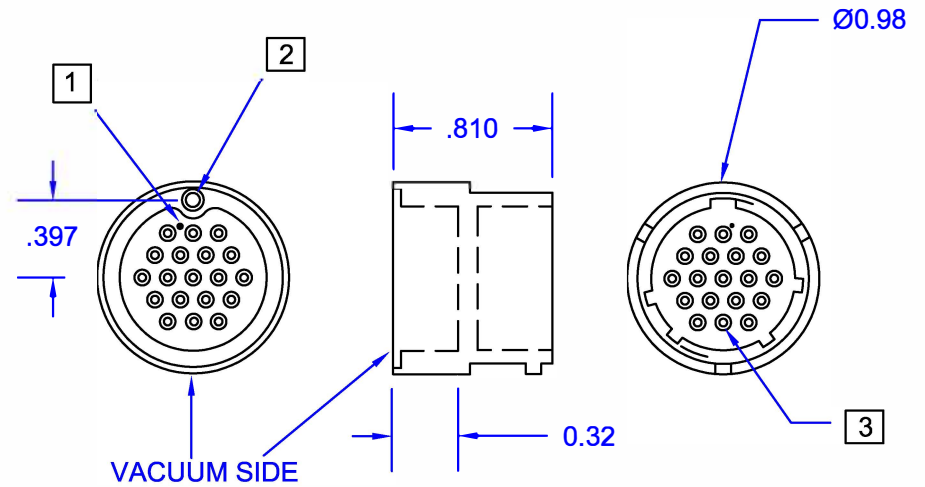

- NOTES:
- 1. CONNECTOR INTERFACE PER MIL-C-26482



Accu-Glass Products Inc.  
 25047 Anza Drive  
 Valencia, CA 91355  
 TEL 818-365-4215  
 FAX 818-365-7074  
 accuglassproducts.com

Notes :

**\* UNCONTROLLED WEB COPY \***

Material <b>304 SS</b>		Title <b>19 Pin C-Type Feedthrough</b>	
Tolerances unless otherwise specified		Drawn By M. Wilson	DWG NO. <b>EAG-19C</b>
Decimal .xx= +/- .005 .xxx= +/- .002	Angular +/- 1°	Approved	Date <b>7-11-07</b>
		Cage Code : 4HCQ8	