

Notes

1. Leak test to 5x10E-10 Standard cc/sec of He
2. Product Specifications... Voltage, 500 VAC / Current, 5 amps per pin maximum @ 20 C (up to 20% of total number of pins) / Temperature / -200 to 250 C / Vacuum, UHV, 1x10E-10 Torr
3. Related Hardware... Copper Gaskets, AG Part No. 200761 / Bolts, Nuts, Washers, AG Part No. 200764
4. Due to feedthrough's straight-through pin construction air-to-vacuum pin positions are reversed (mirrored).
5. Red dashed line indicates standard mating tube ID.

Rev	Description	Date
B	Low temperature specification	20140814 / AL

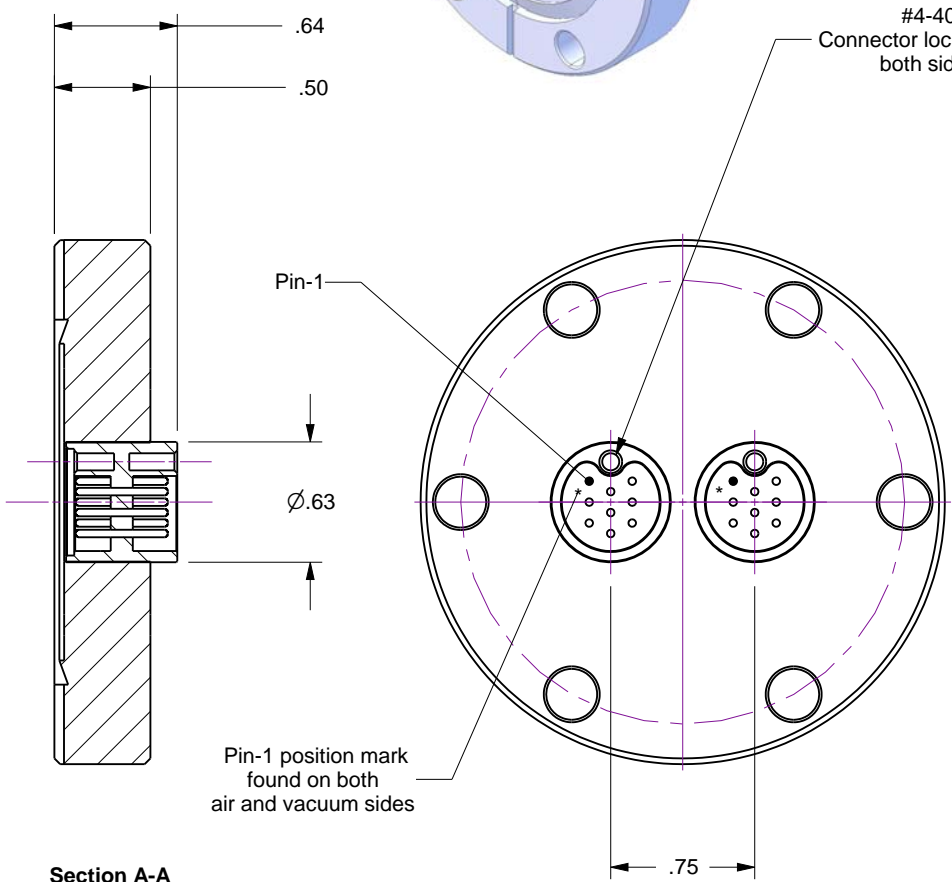
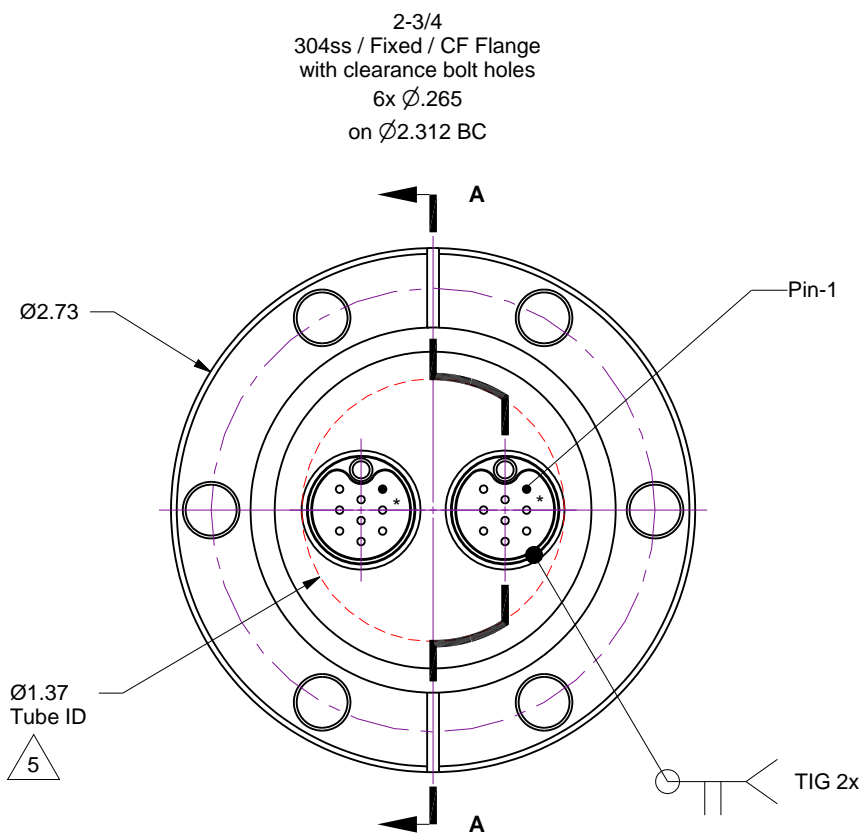
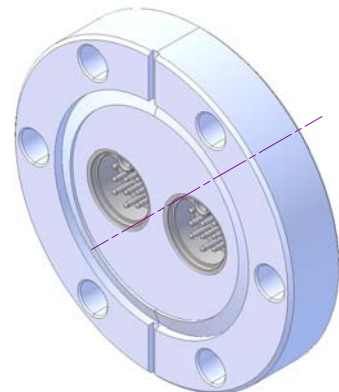

Accu-Glass Products Inc.
25047 Anza Drive
Valencia, CA 91355
T 818-365-4215
F 818-365-7074
www.accuglassproducts.com

UNCONTROLLED WEB DRAWING

Proprietary and Confidential
The information contained in this drawing is the sole property of Accu-Glass, Products Inc. Any reproduction, in part or as whole, without the written permission of Accu-Glass Products, Inc., is strictly prohibited.

Material See Individual Components	
Tolerances, unless otherwise specified	
.X ± .030	Angles ± 0.5°
.XX ± .010	Finish 63Ra
.XXX ± .005	

Title FT, Subminiature-C, 2x 9-Pin, 2.75 CF			
Drawn by Date	Ligeti 8/14/2014	No. 100012	Rev. B
Approved			Sheet