

PROPRIETARY AND CONFIDENTIAL
 THE INFORMATION CONTAINED IN THIS
 DRAWING IS THE SOLE PROPERTY OF
 ACCU-GLASS PRODUCTS INC. ANY
 REPRODUCTION IN PART OR AS WHOLE
 WITHOUT THE WRITTEN PERMISSION OF
 ACCU-GLASS PRODUCTS INC. IS
PROHIBITED.

Rev	Description	Date	Approved

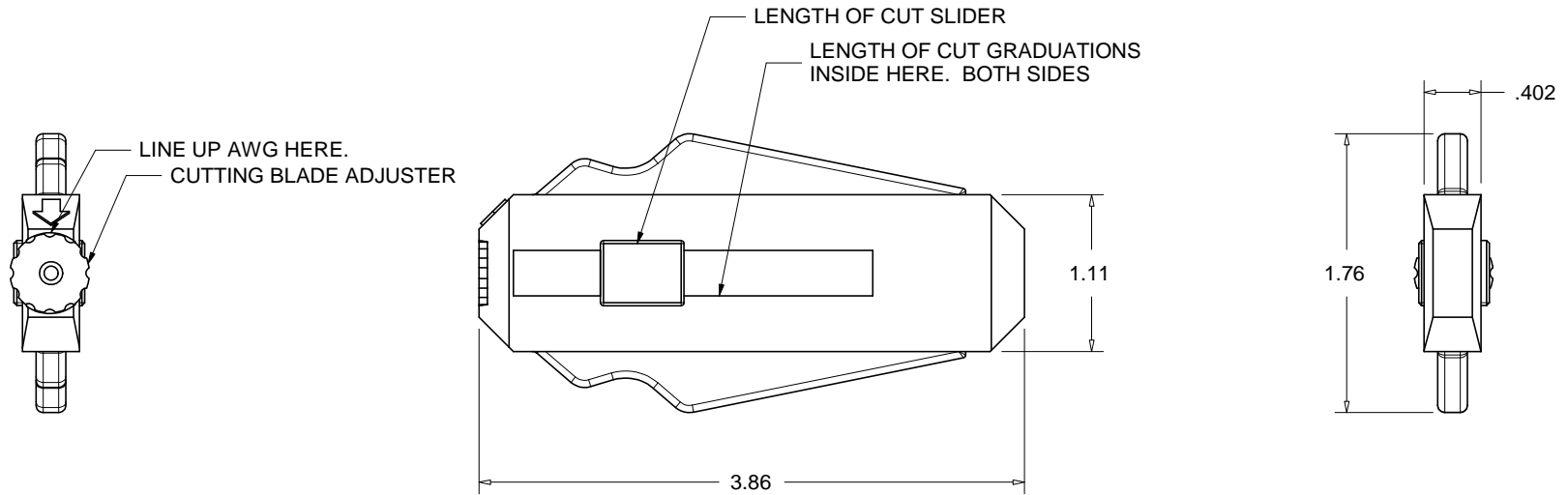
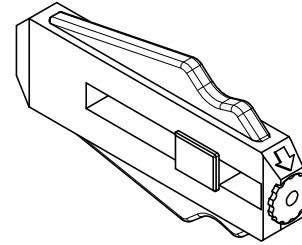

INSTRUCTION FOR USE

1. ADJUST SLIDER TO DESIRED LENGTH OF CUT GRADUATIONS ON INSIDE OF SLOT.
2. ADJUST CUTTING BLADES, LINE UP ARROW TO AWG DESIRED.
3. INSERT WIRE THROUGH HOLE UNTIL IT LOCATES ON SLIDER.
4. SQUEEZE YELLOW HANDLES THEN ROTATE 1/4 TURN IN BOTH DIRECTIONS (1/2 TURN TOTAL MOVEMENT)
5. MAINTAINING SQUEEZE PULL OFF INSULATION.



Accu-Glass Products Inc.
 25047 Anza Drive
 Valencia, CA 91355
 TEL 818-365-4215
 FAX 818-365-7074
 accuglassproducts.com

Notes:

UNCONTROLLED WEB COPY

Material
ASSEMBLY

Tolerances unless otherwise specified.

.X ± .03	Angular: +/- .5°
.XX ± .01	Finish: Min. 63 Ra
.XXX ± .005	

Title: 2030AWG-STR
 WIRE STRIPPER 20-30 AWG WIRE

Drawn By Date	CR 080409	DWG. NO. 100192	Rev. A
Approved	C M	PDFE	Sheet 1 OF 1