

PROPRIETARY AND CONFIDENTIAL
 THE INFORMATION CONTAINED IN THIS DRAWING IS THE SOLE PROPERTY OF ACCU-GLASS PRODUCTS INC. ANY REPRODUCTION IN PART OR AS WHOLE WITHOUT THE WRITTEN PERMISSION OF ACCU-GLASS PRODUCTS INC. IS **PROHIBITED.**

Specifications:

Voltage	500 VDC
Current	5A Max. @ 20°C (per pin up to 20% of total number of pins)
Temperature	-26°C to 150°C (Dependant on O-ring type used)
Vacuum Level	HV 1x10 ⁻⁸ Torr.

Rev	Description	Date	Approved
A	INITIAL RELEASE	020810	C M

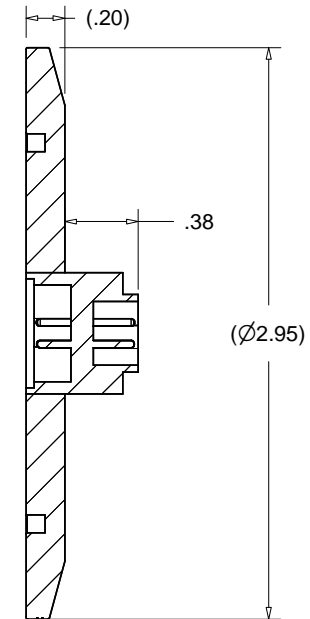
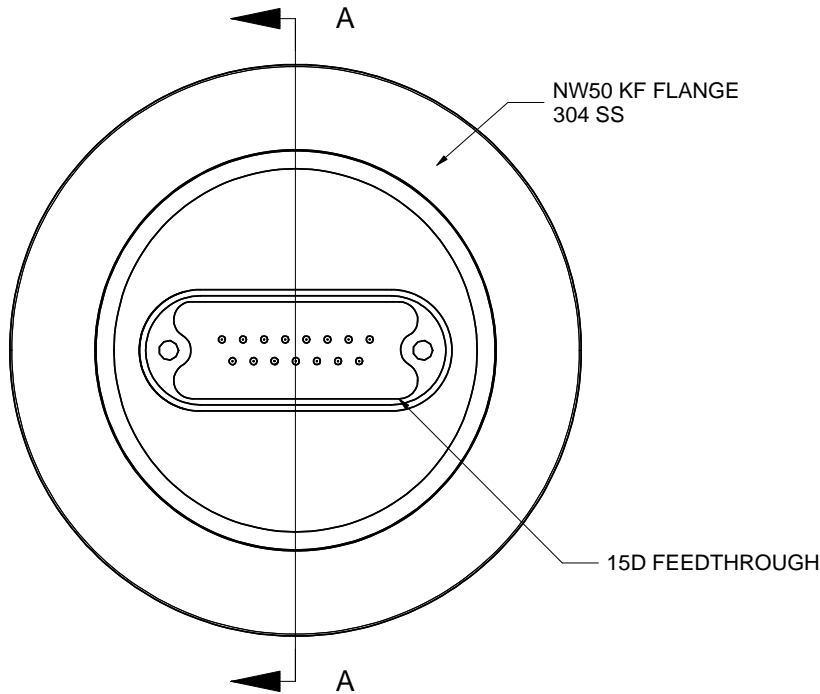
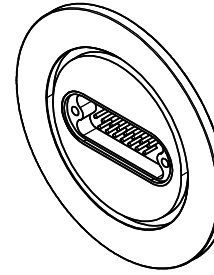

Section A-A

Related Flange Hardware	NW50KF ISO Flange
P/N 202230,	Centering Ring - Stainless / Viton
P/N 202235,	Hinged Clamp - Aluminum



Accu-Glass Products Inc.
 25047 Anza Drive
 Valencia, CA 91355
 TEL 818-365-4215
 FAX 818-365-7074
 accuglassproducts.com

Notes:
 1. No detectable leaks @ 5x10⁻¹⁰ cc/s He.

UNCONTROLLED WEB COPY

Material SEE ABOVE	
Tolerances unless otherwise specified.	
.X ± .03	Angular: +/- .5°
.XX ± .01	Finish: Min. 63 Ra
.XXX ± .005	

Title: 51D-K50 NW50 KF FLANGE WITH 15D FEEDTHROUGH			
Drawn By Date	CR 061809	DWG. NO. 100211	Rev. A
Approved	C M	PDFE	Sheet 1 OF 1