

PROPRIETARY AND CONFIDENTIAL
 THE INFORMATION CONTAINED IN THIS DRAWING IS THE SOLE PROPERTY OF ACCU-GLASS PRODUCTS INC. ANY REPRODUCTION IN PART OR AS WHOLE WITHOUT THE WRITTEN PERMISSION OF ACCU-GLASS PRODUCTS INC. IS **PROHIBITED.**

Specifications:	
Voltage	500 VDC
Current	5A Max. @ 20° C (per pin up to 20% of total number of pins)
Temperature	-200 °C to 250° C
Vacuum Level	UHV 1x10 ⁻¹⁰ Torr.

Rev	Description	Date	Approved
A	INITIAL RELEASE	020810	C M

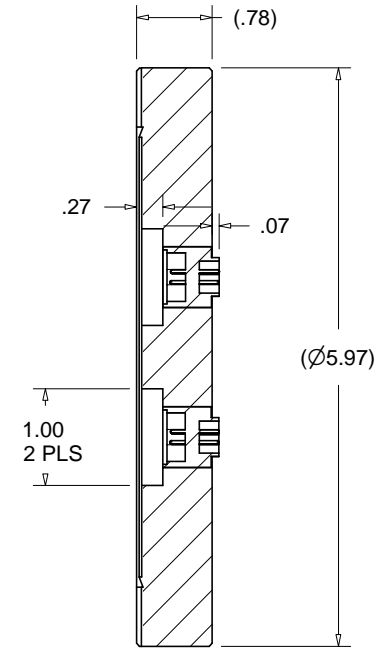
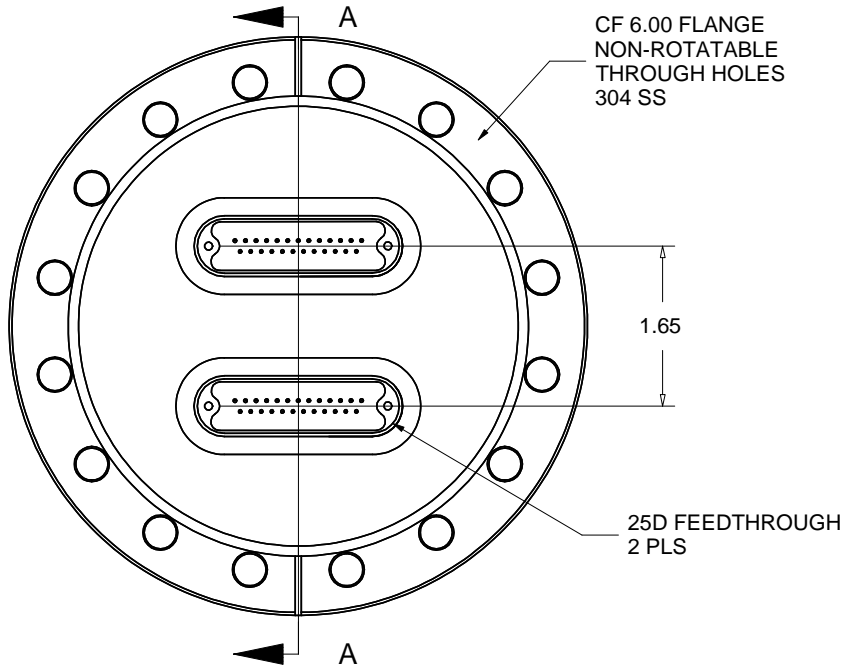
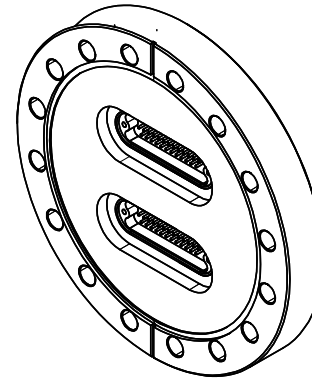

Section A-A

Related Flange Hardware	6.00" CF Flange
P/N 200850,	Copper Gasket
P/N 200853,	Bolts, Nuts and Washers set



Accu-Glass Products Inc.
 25047 Anza Drive
 Valencia, CA 91355
 TEL 818-365-4215
 FAX 818-365-7074
 accuglassproducts.com

- Notes:
 1. DIM'S SYM. ABOUT CENTERLINES
 2. No detectable leaks @ 5x10⁻¹⁰ cc/s He.

Material SEE ABOVE	
Tolerances unless otherwise specified.	
.X ± .03	Angular: +/- .5°
.XX ± .01	Finish: Min. 63 Ra
.XXX ± .005	

Title: 25D2-600 CF 6.00 FLANGE WITH 2 X 25D FEEDTHROUGHS			
Drawn By Date	CR 051509	DWG. NO. 100227	Rev. A
Approved	CM	PDFE	Sheet 1 OF 1

UNCONTROLLED WEB COPY