

PROPRIETARY AND CONFIDENTIAL
 THE INFORMATION CONTAINED IN THIS DRAWING IS THE SOLE PROPERTY OF ACCU-GLASS PRODUCTS INC. ANY REPRODUCTION IN PART OR AS WHOLE WITHOUT THE WRITTEN PERMISSION OF ACCU-GLASS PRODUCTS INC. IS **PROHIBITED.**

PIN NUMBER ASSIGNMENTS
 MALE 25D CONNECTOR

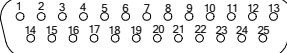

FACE VIEW

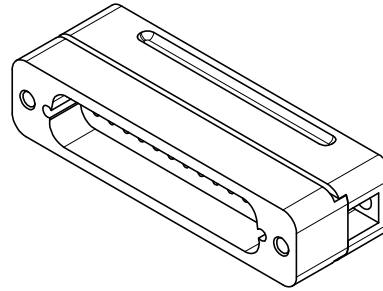

Rev	Description	Date	Approved
A	INITIAL RELEASE	022310	C M

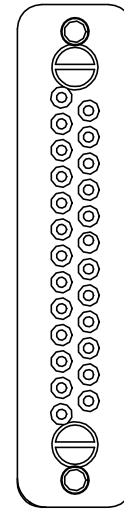
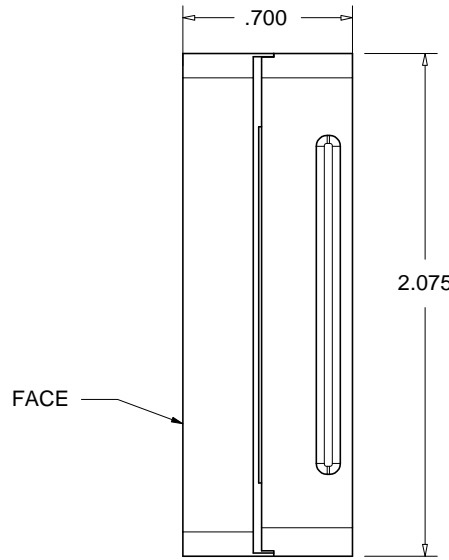
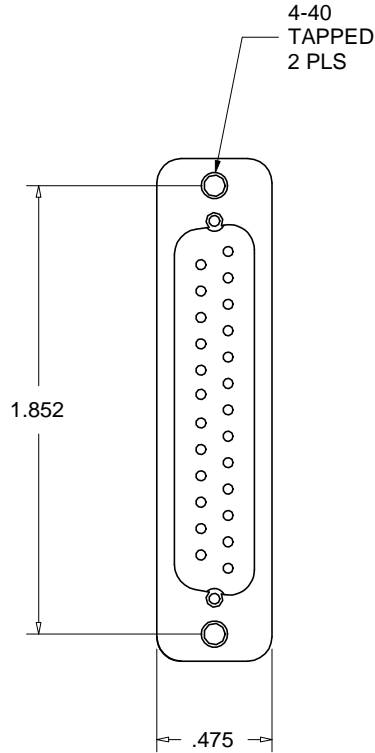

RELATED CONTACTS, TYPE-T1 (MALE)
 P/N 100170, STANDARD, USE WITH 20-24AWG WIRE
 P/N 100171, STANDARD, USE WITH 26-30AWG WIRE
 P/N 100190, CRIMP TOOL FOR TYPE-T1 CONTACTS
 P/N 100465, BACKSHELL STRAIN RELIEF

* NOTE: CONTACT RETAINING COMBS INCLUDED (NOT SHOWN)



Accu-Glass Products Inc.
 25047 Anza Drive
 Valencia, CA 91355
 TEL 818-365-4215
 FAX 818-365-7074
 accuglassproducts.com

Notes:
 1. DIMENSIONS SYMMETRICAL ABOUT CENTERLINES
 2. CONTACTS NOT INCLUDED

UNCONTROLLED WEB COPY

Material PEEK /STAINLESS	
Tolerances unless otherwise specified.	
.X ± .03	Angular: +/- .5°
.XX ± .01	Finish: Min. 63 Ra
.XXX ± .005	

Title: 25D-PKP			
PEEK 25D MALE CONNECTOR ASSEMBLY			
Drawn By Date	CR 2/2/2010	DWG. NO. 100420	Rev. A
Approved	C M	PDFE	Sheet 1 OF 1