

Notes

- 1. Five (5), female shields and female contacts on 25D Subminiature-D connector interface
- 2. Clean, handle and package assembly for UHV service.
- 3. Connector front and back pieces are PEEK (polyether-etherketone) polymer.
- 4. Available in 19 and 39 inch standard lengths, see table for respective part numbers.

Rev	Description	Date
B	Remodeled Part	

Length 'A'	Description	Model	Part No.
19"	5-Lead, 19 Inch Coaxial Cable Assembly	25KAP-5CX-19SC	100640
39"	5-Lead, 39 Inch Coaxial Cable Assembly	25KAP-5CX-39SC	100641

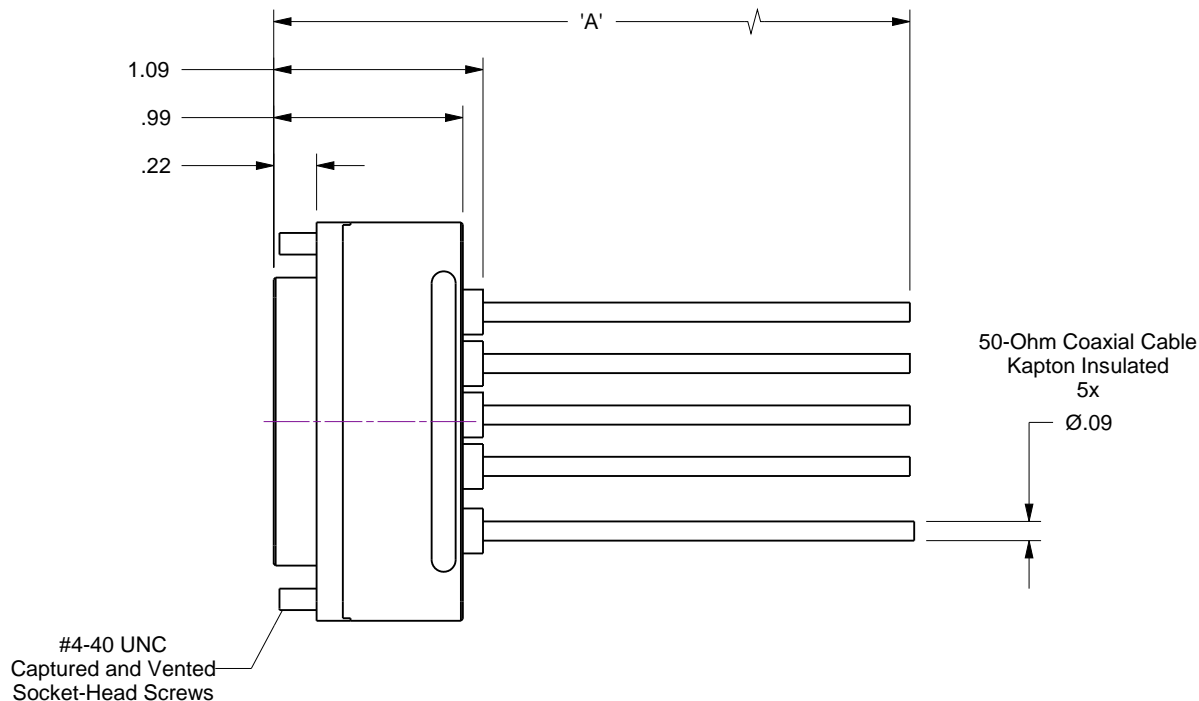
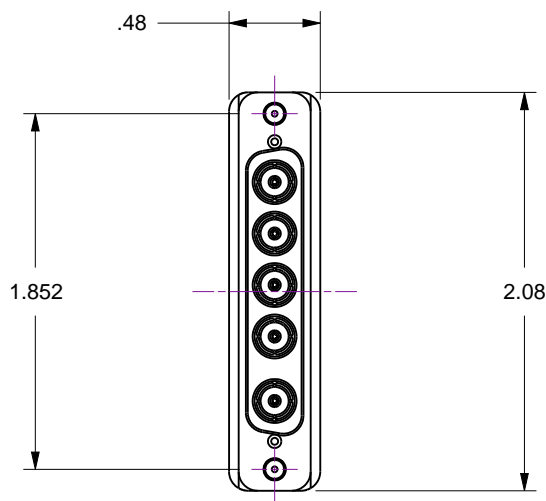
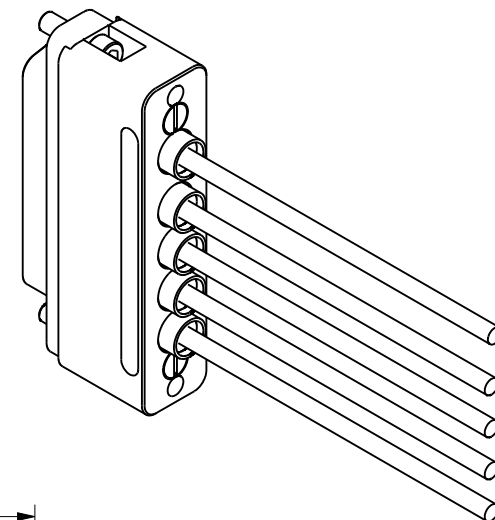

**Accu-Glass Products Inc.**  
 25047 Anza Drive  
 Valencia, CA 91355  
 T 818-365-4215  
 F 818-365-7074  
 www.accuglassproducts.com

**UNCONTROLLED WEB DRAWING**

Proprietary and Confidential  
 The information contained in this drawing is the sole property of Accu-Glass, Products Inc. Any reproduction, in part or as whole, without the written permission of Accu-Glass Products, Inc., is strictly prohibited.

Material See Individual Components	
Tolerances, unless otherwise specified	
.X ± .030	Angles ± 0.5°
.XX ± .010	Finish 63Ra
.XXX ± .005	

Title <b>Cable, 5-Pin Coaxial on 25D Connector</b>			
Drawn by Date	Ligeti 7/15/2014	No. <b>100640</b>	Rev. <b>B</b>
Approved		Sheet	