

**PROPRIETARY AND CONFIDENTIAL**  
 THE INFORMATION CONTAINED IN THIS DRAWING IS THE SOLE PROPERTY OF ACCU-GLASS PRODUCTS INC. ANY REPRODUCTION IN PART OR AS WHOLE WITHOUT THE WRITTEN PERMISSION OF ACCU-GLASS PRODUCTS INC. IS **PROHIBITED.**

**PIN NUMBER ASSIGNMENTS  
 MALE 9D CONNECTOR**

**FACE VIEW**

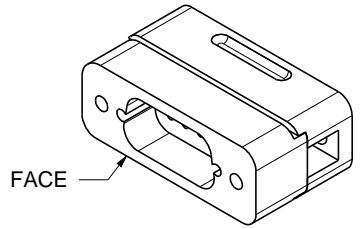

Rev	Description	Date	Approved
A	INITIAL RELEASE		

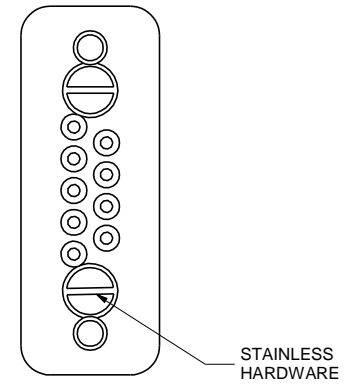
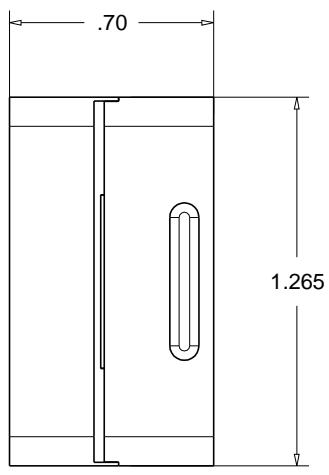
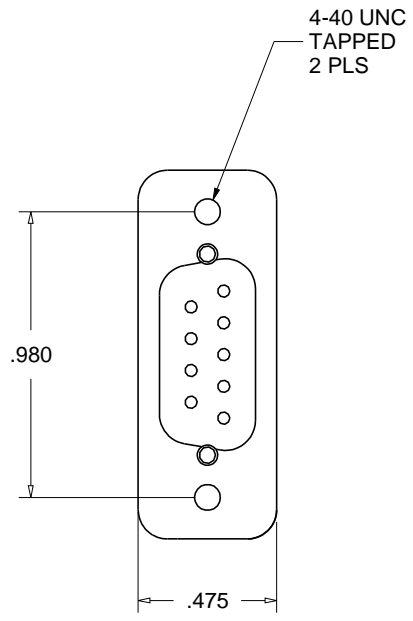

RELATED CONTACTS, TYPE-T1 (MALE)
P/N 100981, CHROMEL THERMAL COUPLE
P/N 100991, ALUMEL THERMAL COUPLE
P/N 100190, CRIMP TOOL FOR TYPE T1 CONTACTS
P/N 112290, PEEK STRAIN RELIEF, 4 TC PAIR

\* NOTE: CONTACT RETAINING COMBS INCLUDED (NOT SHOWN)

Accu-Glass Products Inc.  
 25047 Anza Drive  
 Valencia, CA 91355  
 TEL 818-365-4215  
 FAX 818-365-7074  
 accuglassproducts.com

Notes:  
 1. DIMENSIONS SYMMETRICAL ABOUT CENTERLINES  
 2. CONTACT PINS NOT INCLUDED  
 3. HOLE 3 NORMALLY NOT USED FOR TC APPLICATION

**\*UNCONTROLLED WEB COPY\***

Material <b>PEEK / STAINLESS</b>	
Tolerances unless otherwise specified.	
.X ± .03	Angular: +/- .5°
.XX ± .01	Finish: Min. 63 Ra
.XXX ± .005	

Title: <b>9D-8TC-PPK PEEK 9D MALE TC CONNECTOR ASSEMBLY</b>			
Drawn By Date	CREYNOLDS 031912	DWG. NO. <b>101021</b>	Rev. <b>A</b>
Approved	CM	PDFE	Sheet 1 OF 1