

**PROPRIETARY AND CONFIDENTIAL**  
 THE INFORMATION CONTAINED IN THIS DRAWING IS THE SOLE PROPERTY OF ACCU-GLASS PRODUCTS INC. ANY REPRODUCTION IN PART OR AS WHOLE WITHOUT THE WRITTEN PERMISSION OF ACCU-GLASS PRODUCTS INC. IS **PROHIBITED.**

Rev	Description	Date	Approved
A	INITIAL RELEASE		

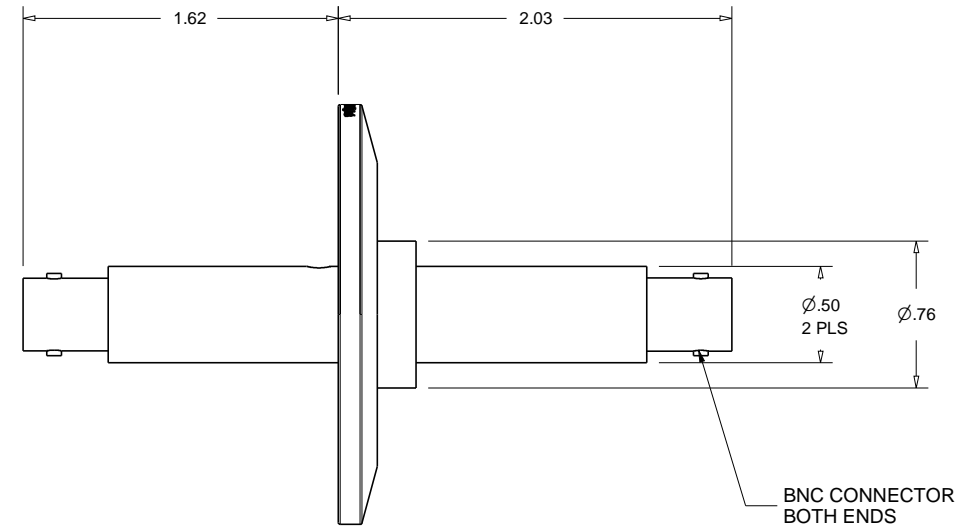

Related Flange Hardware	NW40KF ISO Flange
P/N 202220,	Centering Ring - Stainless / Viton
P/N 202225,	Hinged Clamp - Aluminum

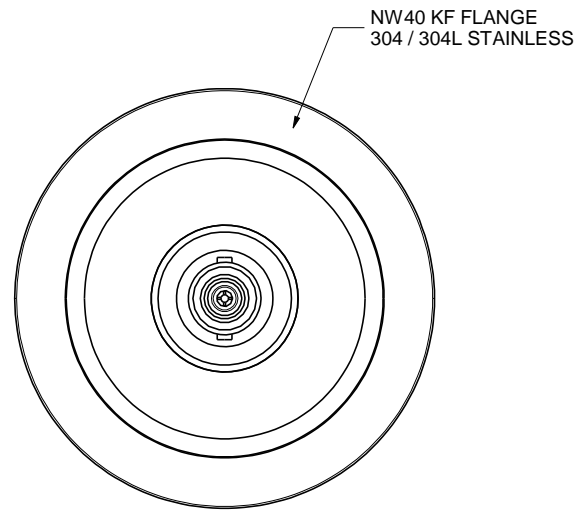
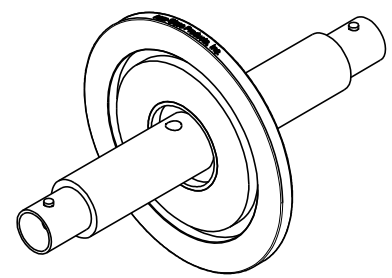

Accu-Glass Products Inc.  
 25047 Anza Drive  
 Valencia, CA 91355  
 TEL 818-365-4215  
 FAX 818-365-7074  
 accuglassproducts.com

Notes:  
 1. DIMENSIONS SYMMETRICAL ABOUT CENTERLINES  
 2. No detectable leaks @  $5 \times 10^{-10}$  cc/s He.

**\*UNCONTROLLED WEB COPY\***

Material assembly		Title: <b>2BNC-GS-K40</b> <b>NW40 KF, BNC DOUBLE, GROUNDED SHIELD</b>	
Tolerances unless otherwise specified.		Drawn By Date	CR 4/4/2012
.X ± .03	Angular: +/- .5°	DWG. NO.	110146
.XX ± .01	Finish: Min. 63 Ra	Approved	C M
.XXX ± .005		PDFE	Sheet 1 OF 1
		Rev.	A