

PROPRIETARY AND CONFIDENTIAL
 THE INFORMATION CONTAINED IN THIS DRAWING IS THE SOLE PROPERTY OF ACCU-GLASS PRODUCTS INC. ANY REPRODUCTION IN PART OR AS WHOLE WITHOUT THE WRITTEN PERMISSION OF ACCU-GLASS PRODUCTS INC. IS **PROHIBITED.**

Rev	Description	Date	Approved
A	INITIAL RELEASE		

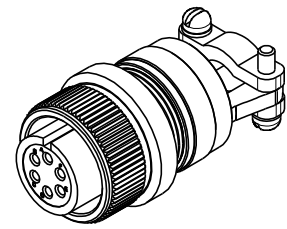

CONNECTOR SHELL IS ALUMINUM WITH AN ELECTROLESS NICKEL FINISH

MEDIUM DIAMOND KNURL

LOCATIONS PER Mil-C-5015 SPECIFICATIONS

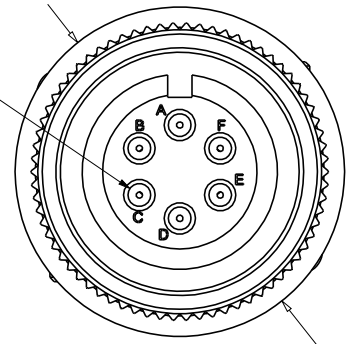

Ø1.13

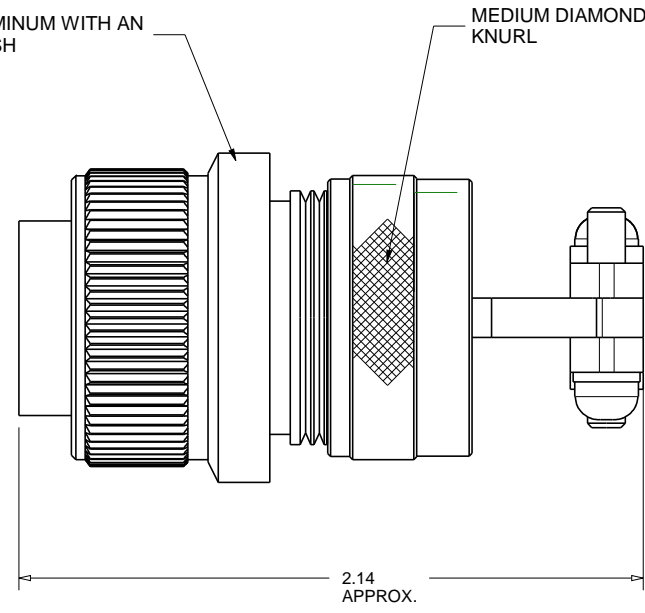

2.14 APPROX.

RELATED CONTACTS, TYPE-T5p
P/N 110701, CONTACT SOCKET TYPE T5p .066 WIRE WELL
P/N 110702, CRIMPING TOOL FOR TYPE T5 CONTACTS
P/N 111614, EXTRACTION TOOL FOR TYPE T5 CONTACTS
P/N 111613, INSERTION TOOL FOR TYPE T5 CONTACTS

NOTES:
 DOES NOT INCLUDE CONTACT SOCKETS
 DOES INCLUDE PLASTIC INSERTION / EXTRACTION TOOL
 WILL ACCEPT WIRES UP TO 16AWG



Accu-Glass Products Inc.
 25047 Anza Drive
 Valencia, CA 91355
 TEL 818-365-4215
 FAX 818-365-7074
 accuglassproducts.com

Notes:
 1. DIMENSIONS SYMMETRICAL ABOUT CENTERLINES

Material assembly	
Tolerances unless otherwise specified.	
.X ± .03	Angular: +/- .5°
.XX ± .01	Finish: Min. 63 Ra
.XXX ± .005	

Title: 6C-AIR AIR SIDE 6C FEMALE CONNECTOR ASS'Y			
Drawn By Date	CR 1/17/2012	DWG. NO. 110711	Rev. A
Approved	C M	PDFE	Sheet 1 OF 1

*** UNCONTROLLED WEB COPY ***