

PROPRIETARY AND CONFIDENTIAL
 THE INFORMATION CONTAINED IN THIS DRAWING IS THE SOLE PROPERTY OF ACCU-GLASS PRODUCTS INC. ANY REPRODUCTION IN PART OR AS WHOLE WITHOUT THE WRITTEN PERMISSION OF ACCU-GLASS PRODUCTS INC. IS **PROHIBITED.**

Rev	Description	Date	Approved
A	INITIAL RELEASE		

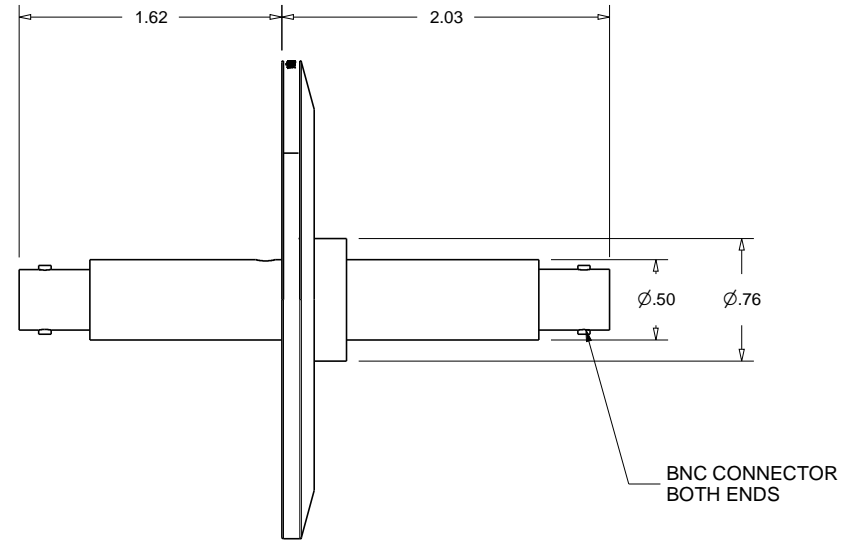

Related Flange Hardware	NW50KF ISO Flange
P/N 202230,	Centering Ring - Stainless / Viton
P/N 202235,	Hinged Clamp - Aluminum

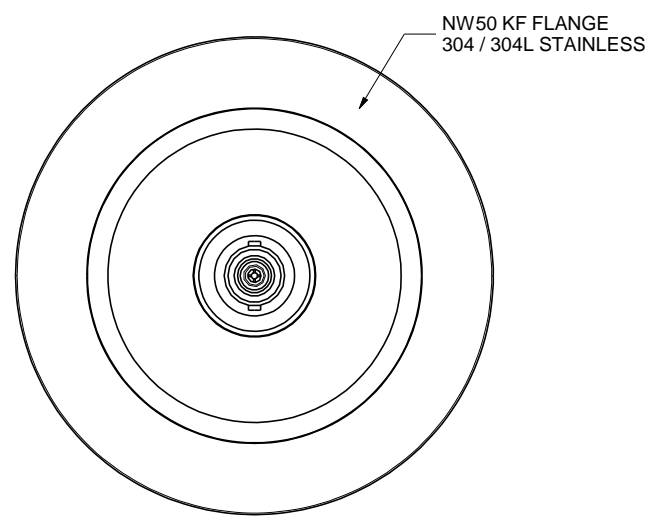
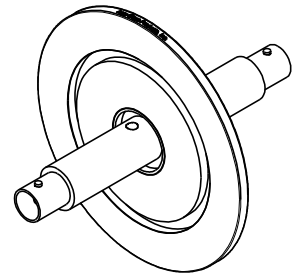

Accu-Glass Products Inc.
 25047 Anza Drive
 Valencia, CA 91355
 TEL 818-365-4215
 FAX 818-365-7074
 accuglassproducts.com

Notes:
 1. DIMENSIONS SYMMETRICAL ABOUT CENTERLINES
 2. No detectable leaks @ 5×10^{-10} cc/s He.

UNCONTROLLED WEB COPY

Material assembly		Title: 2BNC-GS-K50	
Tolerances unless otherwise specified.		NW50 KF, BNC DOUBLE, GROUNDED SHIELD	
.X ± .03	Angular: +/- .5°	Drawn By Date	CR 4/4/2012
.XX ± .01	Finish: Min. 63 Ra	DWG. NO.	111325
.XXX ± .005		Approved	C M
		Rev.	A
		PDFE	Sheet 1 OF 1