

Notes

- 1. Leak test to 5x10E-10 Standard cc/sec of He
- 2. Protect knife-edge (seal surface) from damage.

Rev	Description	Date
A	Initial Release	

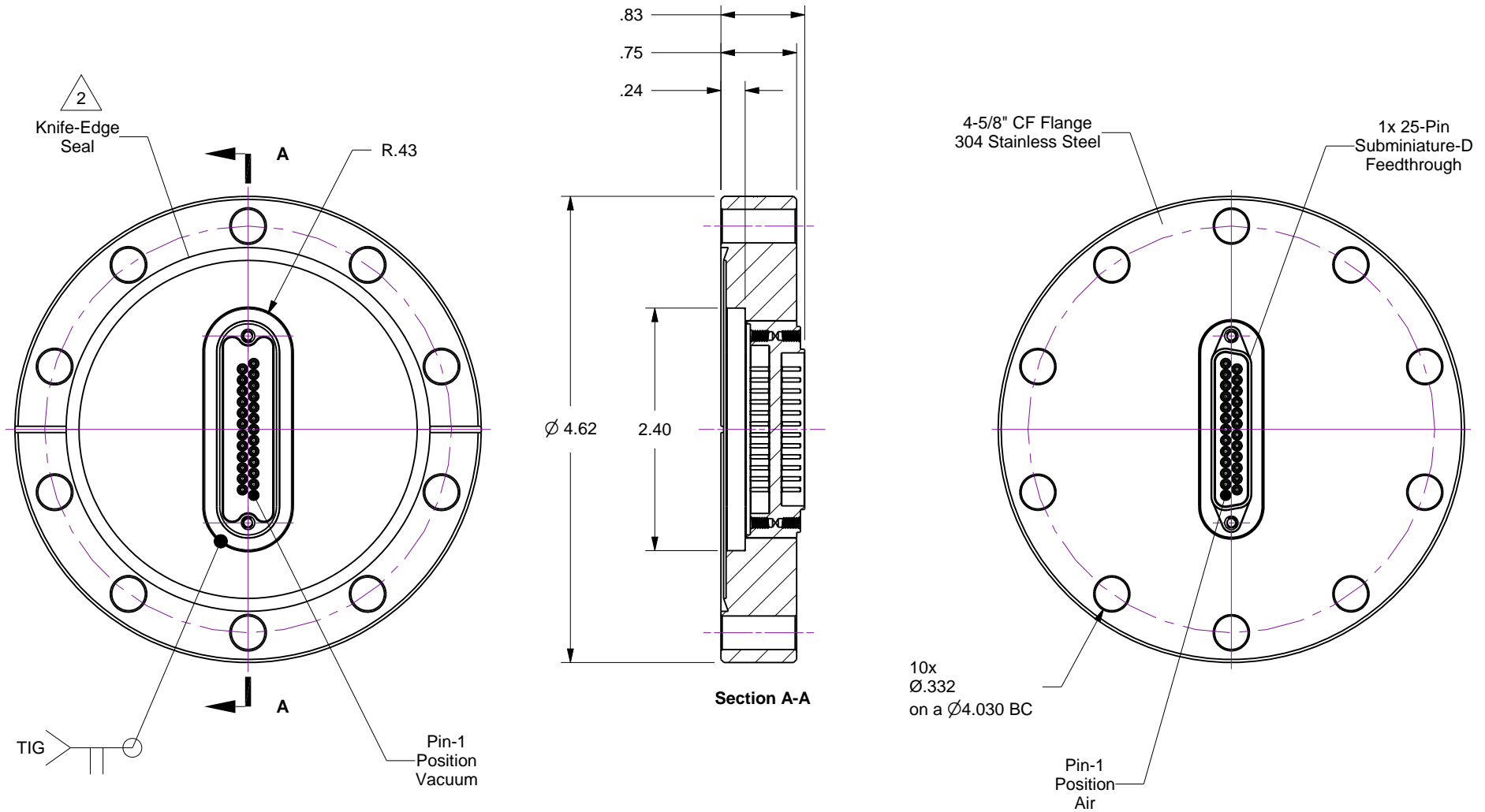

Accu-Glass Products Inc.
 25047 Anza Drive
 Valencia, CA 91355
 T 818-365-4215
 F 818-365-7074
 www.accuglassproducts.com

UNCONTROLLED WEB DRAWING

Proprietary and Confidential
 The information contained in this drawing is the sole property of Accu-Glass, Products Inc. Any reproduction, in part or as whole, without the written permission of Accu-Glass Products, Inc., is strictly prohibited.

Material See Individual Parts	
Tolerances, unless otherwise specified	
.X ± .030	Angles ± 0.5°
.XX ± .010	Finish 63Ra
.XXX ± .005	

Title 25-Pin Subminiature-D Feedthrough on 4.62 CF			
Drawn by Date	Ligeti 10/29/2014	No. 112665	Rev. A
Approved			Sheet