

Notes

- 1. Leak Tested To 5x10E-10 standard cc/se of He.
- 2. Dimensions Symmetrical About Centerlines.
- 3. This is a vacuum safety 'over pressurization prevention' device. As such, ruptured discs can not be repaired, and must be replaced with a completely new unit.
- 4. Be Careful Of Burst Disc Foil, It Is Very Fragile

Rev.	Description	Date	Made By	Approval
A	Initial Release	3/25/2009	CR	CM
B	Changed Burst Disc And Adapter To New Version	6/30/2020	Farrell	

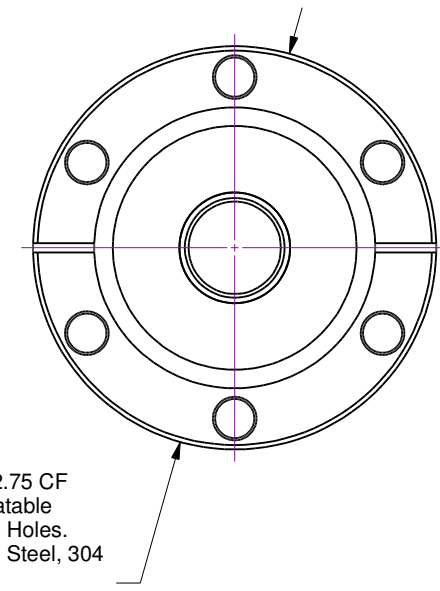
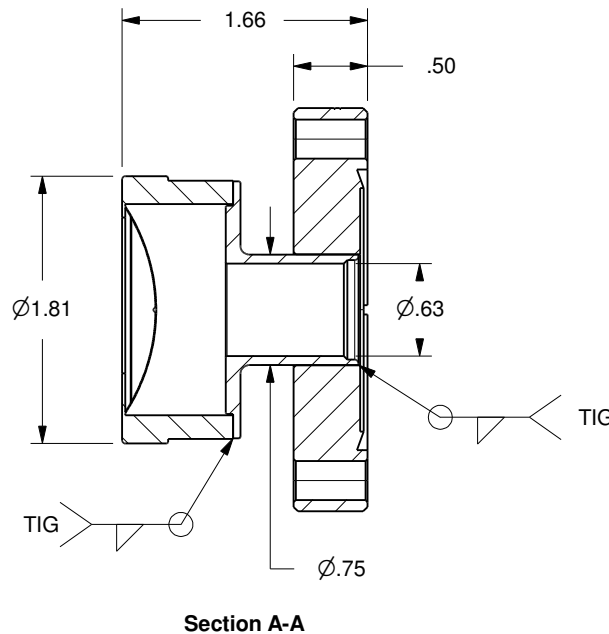
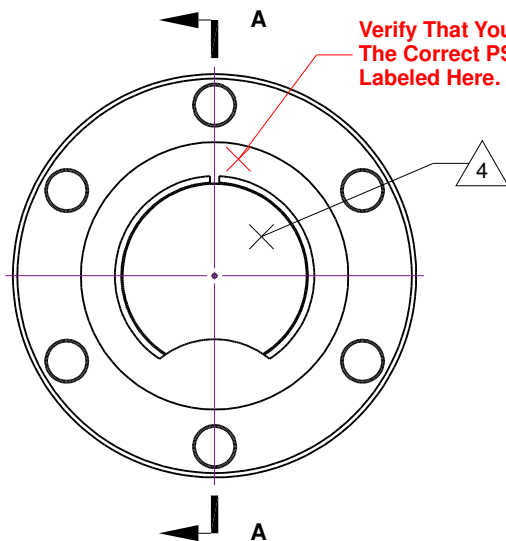
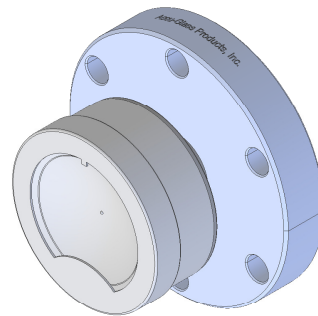

Accu-Glass Products Inc.
 25047 Anza Drive
 Valencia, CA 91355
 T 818-365-4215
 F 818-365-7074
 www.accuglassproducts.com

UNCONTROLLED WEB DRAWING

Proprietary and Confidential
 The information contained in this drawing is the sole property of Accu-Glass, Products Inc. Any reproduction, in part or as whole, without the written permission of Accu-Glass Products, Inc., is strictly prohibited.

Material Stainless Steel	
Tolerances, unless otherwise specified	
.X ± .030	Angles ± 0.5°
.XX ± .010	Finish 63Ra
.XXX ± .005	

Title PBD-275			
Drawn by Date	CR 3/25/2009	No. 112071	Rev. B
Approved	C M	Sheet 1 OF 1	